

Prok dv's®
Total reliability in power system protection & monitoring
... a mark of quality



Product Catalogue



www.prokdvs.com

An ISO 9001 : 2008 Certified Company

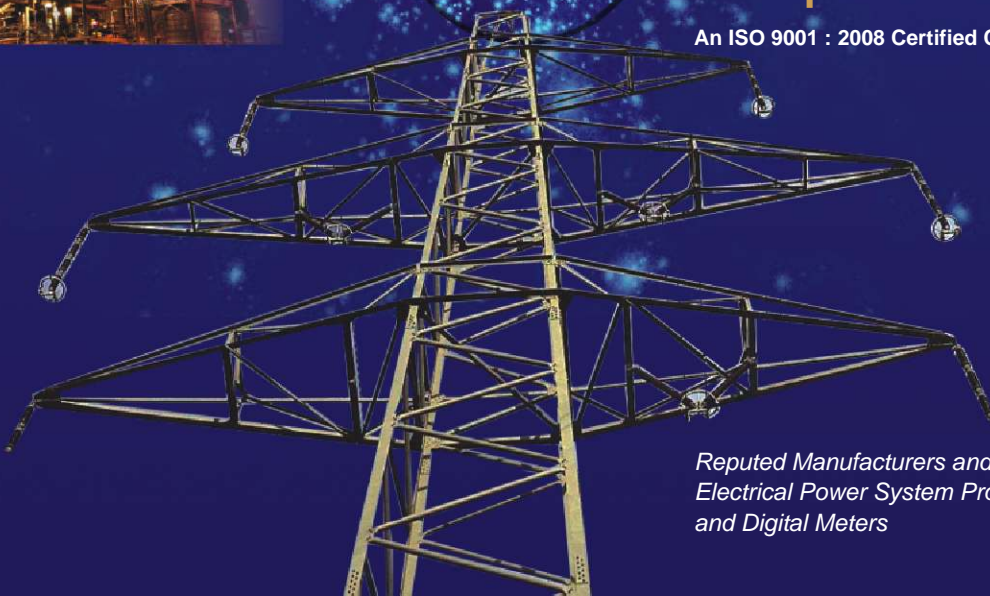

*Reputed Manufacturers and Exporters of
Electrical Power System Protection Relays
and Digital Meters*



Company Profile

Prok Devices Private Limited a ISO 9001-2008 Certified Company established in the year 1991, set up by four highly motivated & experienced professionals in the field of electrical and electronic engineering. With over eight years of experience in Manufacturing, Quality Control & Inspection / Testing & Calibration / Design & Development / Sales & Marketing, the company backed with technical abilities of electrical engineers. Prok Devices ear marked itself as a blue chip company in Indian & global business scenario within a decade of its establishment.

Prok Devices is reputed for its well trained technical team with an excellent 24x7 service back-up. The strengths of the technical team relies on its vast & varied field experience gained by number of electrical & electronic engineers working in Production & Quality Control.

Prok Devices as a brand has functioned with the registered trade mark **Prok dv's**[®] as a reputed manufacturer of solid state and micro controller based protection relays and digital meters used in power system applications. The R&D wing with its in house Design & Development team is designing & converting most of the existing product line from solid state version to state-of-the art micro controller based versions.

The reputed **Prok dv's**[®] brand products are exported to many International destinations and the company has participated in a number of National & International Exhibitions Conferences & Seminars having won various awards, grants and certifications.

All our products are approved with reputed and leading Technical Consultants, Electricity Boards, Public Sectors, OEM's.. Etc,

Prok Dv's Products are widely used in Major projects like Mining, Cement, Steel, Oil Refineries, Software Industries, Sub-Station, Power Plants, Industries, Commercial & High Rise Buildings, Residential & Educational Institutions.

The company is in lieu with like minded global partners & JV's to implement the trend with ongoing technology in the field of power system protection.

Prok Devices Pvt Ltd which swears by Quality as its maiden name has proven its track record by obtaining International quality certification & programs. Most of the products are type tested as per National / International Standards at Authorised Lab's in INDIA like C.P.R.I , E.T.D.C., L.R.D.E., SAMEER ..etc.,



PRODUCT RANGE



DESIGN / STATE - OF - THE - ART	PRODUCTS	Page No.
A. Microprocessor Based & Solid State	■ EARTH LEAKAGE RELAY with CORE BALANCE CURRENT TRANSFORMER	4
B. Microprocessor Based	■ EARTH FAULT RELAY [DMT, IDMT & Instantaneous]	6
	■ EARTH FAULT RELAY with CORE BALANCE CURRENT TRANSFORMER [DMT, IDMT & Instantaneous]	
Solid State	■ EARTH FAULT RELAY [DMT & Instantaneous]	6
	■ EARTH FAULT RELAY with CORE BALANCE CURRENT TRANSFORMER [DMT & Instantaneous]	
C. Microprocessor Based	■ RESTRICTED EARTH FAULT RELAY	7
D. Microprocessor Based	■ OVER CURRENT RELAY [DMT, IDMT & Instantaneous]	8
E. Microprocessor Based	■ NUMERICAL OVER & UNDER VOLTAGE RELAY with NEGATIVE PHASE SEQUENCE PROTECTION	9
F. Microprocessor Based	■ NUMERICAL OVER CURRENT & EARTH FAULT RELAY	10
G. Microprocessor Based	■ AC VOLTAGE RELAY - LVM Series	12
H. Microprocessor Based	■ REVERSE POWER RELAY	13
I. Microprocessor Based	■ FREQUENCY RELAY	14
J. Microprocessor Based	■ INTELLIGENT POWER FACTOR CORRECTION RELAY	15
K. Microprocessor Based & Solid State	■ VOLTAGE RELAY - VD Series	16
L. Solid State	■ PHASE FAILURE RELAY	18
M. Solid State	■ TAP POSITION INDICATOR	19
N. Solid State	■ DIGITAL METERS	20
O. Solid State	■ THREE PHASE ENERGY METER Counter Type	22
P. Microprocessor Based	■ THREE PHASE ENERGY METER LCD Type	23
P. Microprocessor Based	■ THREE PHASE ENERGY METER DUAL	25
Q. Microprocessor Based	■ DUAL ENERGY METER WITH POWER MONITOR	26
R. Microprocessor Based	■ VAF METER	27
S. Microprocessor Based	■ AUTO SOURCE CHANGE OVER CUM CURRENT LIMITER [ACCL]	28
T. Solid State	■ BATTERY CHARGERS [Switch mode power supplies]	30
U.	■ DIMENSIONAL DRAWINGS	31



Earth Leakage Relay

IEEE Device Code - 64

FEATURES

- Consistent reliability with accuracy
- Fixed or variable sensitivity
- Detection of CBCT open (in μP based model only)
- Continuous monitoring and display of leakage current (in μP based model only)
- LED/LCD display for visual indication of fault
- High barrier connector at rear end for easy termination and safety standard
- Test & Reset facility for testing healthiness of the relay
- Tamper proof polycarbonate cover in the front

APPLICATIONS

- Earth leakage protection for feeders/motors/generators/transformer/mobile operating equipments
- Protection of hazardous sensitive environments like oil refineries/chemical platforms/pulp industries and general electrical distribution.
- Protection for mining and control engineering.
- Software and telecom sector

CLASSIFICATION BASED ON DESIGN:

- A) Solid state ELRs -EL / DEL Series. (D stands for-Din mounting)
- B) Microprocessor ELR MPEL / DMPEL Series (D stands for-Din mounting)



INTRODUCTION: Earth Leakage Currents give rise to generation of heat and results in progressive failure of insulation, which leads to earth faults, sparking flashovers deterioration of earthing and finally results in catastrophic fires which can destroy costly equipments, gadgets and precious lives. It is therefore essential to detect earth leakage currents well below they cross the threshold limits and isolate the circuit in the event of leakages.

Prok dv's make Earth Leakage Relays (ELR) with Core Balance Current Transformer (CBCT) are used to detect leakage currents in electrical power systems. ELR transmits a signal to activate the trip coil of the MCCB/ACB/OCB/CONTACTOR in the event of earth leakage, resulting in automatic isolation of the load. ELR have been widely used and accepted because of field adaptability and are economic.

PRINCIPLE OF OPERATION: ELR employs core balance current transformer (CBCT) to sense the leakage current. The (CBCT) is mounted externally and load current carrying cable are passed through the (CBCT). Ideally in a leakage free system the incoming and outgoing currents are equal and opposite in direction, which means that the vector sum of the three phase currents is zero and can be expressed as

$$\vec{I}_r + \vec{I}_y + \vec{I}_b = 0 \text{ for 3 phase 3 wire system}$$

$$\vec{I}_r + \vec{I}_y + \vec{I}_b + \vec{I}_n = 0 \text{ for 3phase 4 wire system.}$$

For the above condition the CBCT produces zero resultant magnetic flux keeping the system healthy.

In case of earth leakage either due to insulation degradation / chemical corrosion etc. the vector sum of currents is not zero and CBCT generates voltage which is fed to the ELR.

This signal is compared with the set value of leakage current and trip command is initiated if the leakage current is more than the set values of current and time.

It is worthwhile to emphasize that the unequal /unbalanced loading on phases does not effect the vector sum and as such there is no difficulty in the use of ELR on electrical distribution system with unbalanced loading.

Earth leakage relay for IT,BT, UPS application, mining, cement, petroleum & oil refineries, steel , paper& pulping industries :

Prok dvs recommends the use of μP based Earth Leakage Relays with CBCT for the above applications for greater Reliability and user friendly.



Earth Leakage Relay

IEEE Device Code - 64



PARAMETERS	TYPE & RANGE : EL / DEL series (Solid state)	MPEL / DMPEL Series (Microprocessor based)
CURRENT SETTING RANGE	Variable: 30-300mA (EL-02) 30-3000mA (EL-05) 50-2000mA(ELSPL-52) 300-3000mA(EL-03) 1-4A(EL-04) 1-8A(EL-01) 1-10A(EL-06) 4-12A(EL-07) Fixed: 30mA, 100mA, 500mA & User specified.	300mA-12A -(MPEL-01) 30mA-3.0 A - (MPEL-02) (18- steps .)
TRIPPING TIME	Variable:0.15 -3.0 Sec. Fixed:100mS,500mS, 1Sec& 3Sec	0.0 Sec-5 Sec Step size- 0.05Sec.
AUXILIARY VOLTAGE	110V,230V,415V,550V AC 50Hz.(-15% to+ 20%) 24V, 110V & 220V DC	85-275V AC/DC 415V & 550V. AC
COMMUNICATION WITH MODBUS PROTOCOL RS-485	NA	Device ID: 1-31 Baud Rate:9600 Protocol: Modbus
CORE BALANCE CURRENT TRANSFORMER TYPE	Tape Wound or Resin Cast	Moulded Case or Resin Cast
CBCT STANDARD SIZE Internal Diameter	CIRCULAR: 40mm,65mm,100mm,150mm 200mm,250mm & 300mm RECTANGULAR: User specified.	CIRCULAR: 40mm,65mm,100mm,150mm 200mm,250mm & 300mm RECTANGULAR: User specified.
CONTACT RATING	8A 250V AC/ 8A 30V DC 1C/O or 2C/O	8A 250V AC/ 8A 30V DC 2C/O
MOUNTING	Flush / Din	Flush / Din
DIMENSION	Flush: 96 x 96 x 70mm Din: 75 x 95 x 75 mm (W x H x D)	Flush: 96 x 96 x 70mm Din: 80 x 94 x 76mm (W x H x D)
PANEL CUT OUT(FLUSH)	90 x 90 + .1mm	90 x 90 + .1mm
OPERATING TEMPERATURE	-5° C to + 55° C	-5° C to + 55° C
REFERENCE STANDARDS	IEC 60255 / IEC 755 a) IEC-755 clause 8.3 Verification of operating Characteristics (Perf.test) b) Insulation test IEC-60255 Insulation resistance test - As per IEC-60255-CI-5&7 Di-electric test- As per IEC 60255-CI-5&6 Impulse Voltage test - As per IEC-60255-CI-5&8	IEC 60255 / IEC 755 a) IEC-755 clause 8.3 Verification of operating characteristics (Perf.test) b) Insulation test IEC-60255 Insulation resistance test - As per IEC-60255-CI-5&7 Di-electric test- As per IEC-60255-CI-5&6 Impulse Voltage test - As per IEC-60255-CI-5&8



Prok dv's®

Earth fault Relay Type : EFSPL / MPEFSPL

IEEE Device code-50N

FEATURES:

µP BASED EFR

- Compact
- IDMT (4 IEC curves) & Definite time
- Wide setting ranges
- Fully digital acquisition of data
- LCD display of operated current
- Rugged and tropicalized design

SOLID STATE

- Static device
- Definite time
- Wide setting ranges
- Compact in size
- LED indication of Fault
- Rugged & tropicalized Design



APPLICATIONS

- Feeder/Distributor control panel
- Generator control panel

PARAMETERS	MPEFSPL/ DMPEFSPL (µP BASED)	EFSPL/DEFSPL (Solid state)
RATED CURRENT	1A or 5 A Field selectable	1A or 5 A Factory set
IDMT CURVES	IDMT(NI,3.0 SEC,1.3SEC & LTD) & Definite time Instantaneous	Definite time Instantaneous
PLUG SETTING RANGE	5% - 80% in steps of 5%	10% - 80% insteps of 10%
TMS	0.1 to 2.0 insteps of 0.05	N A
DEFINITE TIME	00.00 to 20.00sec Insteps of 00.10sec	0.15 to 3 sec (6steps)
INSTANTANEOUS TIME	< 40ms	<100ms
FREQUENCY	50Hz	50Hz
BURDEN ON CT	<0.2VA	<0.2VA
AUXILIARY VOLTAGE	85-275V AC/DC	110V/230 V/415AC
CBCT FOR EFR	CIRCULAR: 40mm,65mm,100mm, 150mm, 200mm,250mm &300mm With secondary 1 Amp only	CIRCULAR: 40mm,65mm,100mm 150mm, 200mm,250mm &300mm With secondary 1 Amp only
RELAY OUTPUT	2 C/O, 250 V, 8A AC 30 V , 8A DC	1 C/O or 2C/O ,250V, 8A AC 30V, 8 A DC
OPERATING TEMPERATURE	-5° C to + 55° C	-5 ° C to + 55° C
MOUNTING	Flush / Din rail	Flush / Din rail
DIMENSIONS IN MM	FLIUSH:96X96X70mm DIN:75X95X75 m m (WXHXD)	FLUSH:96x96x70 mm DIN: 80X94X76mm (WXHXD)
PANEL CUTOUT IN MM (FLUSH)	90X90+0.1mm	90X90+0.1mm

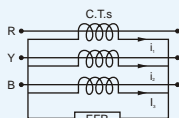

FIG A

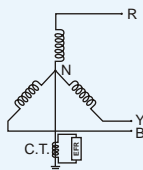

FIG B

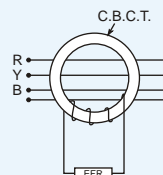

FIG C

RESTRICTED EARTH FAULT RELAY

IEEE CODE 87N



FEATURES:

- Microcontroller based design
- Wide setting ranges
- Auxiliary voltage 85 -275 AC/DC
- Rugged and Compact design
- 8 character back lit LCD display
- Display of the fault current

APPLICATIONS:

- Transformer and generator protection



SPECIFICATIONS

PARAMETER	Type: MPREFR - Microprocessor based
RATED CURRENT	5 Amps
PLUG SETTING RANGE	5 % to 80 % of the relay rating.
OPERATING TIME	Instantaneous (< 40 mS)
AUXILIARY VOLTAGE	85-275 V AC/DC
BURDEN	< 0.2 VA
OUT PUT RELAY	2 C/o output relay, 250V 8A AC, 30V,8A DC
COMMUNICATION (OPTIONAL)	Modbus, RS-485
OPERATING TEMP	- 5° to +55° C
FREQUENCY	50 HZ
DIMENSION	96 x 96 x 70 mm
PANEL CUT OUT	90 x 90 + 0.1 mm



OVER CURRENT RELAY TYPE : MPOCSPL

IEEE Device code-50

FEATURES:

- Compact
- IDMT (4 IEC curves) & Definite time
- Wide setting ranges
- Fully digital acquisition of data
- LCD display of operated current
- Tropicalized and rugged design

APPLICATIONS

- Feeder/Distributor control panel
- Generator control panel



SPECIFICATIONS

PARAMETER	MPOCSPL/DMPOCSPL Microprocessor Based
RATED CURRENT	1A or 5 A
IDMT CURVES (IEC)	IDMT(NI,3.0 SEC,1.3SEC & LTD) & Definite time / Instantaneous
PLUG SETTING RANGE	50% - 200% in steps of 5%
TMS	0.1 to 2.0 insteps of 0.05
DEFINITE TIME	00.00 to 20.00sec Insteps of 00.10sec
INSTANTANEOUS TIME	<40ms
RATED FREQUENCY	50Hz
BURDEN ON CT	<0.2VA
AUXILIARY VOLTAGE	85-275V AC/DC
RELAY OUTPUT	2 C/O 250 V , 8A AC 30 V 8A DC
OPERATING TEMPERATURE	-5 ° C to +55° C
MOUNTING	Flush/ Din rail
DIMENSIONS IN MM	FLUSH:96X96X70 mm DIN:75X95X75 mm (WXHxD)
PANEL CUTOUT IN MM	90X90+0.1mm

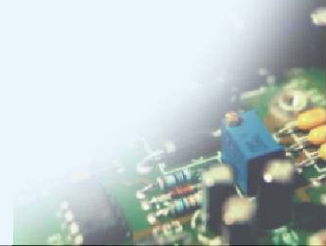

Numerical Over and Under Voltage relay



FEATURES:

- IDMT & Definite time characteristics
- Negative phase sequence detection
- High Pickup/drop off ratio
- Modular Integrated Draw Out System
- Nonvolatile memory for data retention
- Wide range of system voltages
- High speed feature for under voltages and over voltages
- 2 line, 16 character back lit LCD display and key pad.
- Very low burden on measurement and Aux circuits
- Accurate and reliable measurement of voltages
- Field selectable system voltages



APPLICATIONS:

- Protection of motor and generators
- Main or backup protection
- For detection of OV & UV in power plants and distribution system
- Protection of transformer panel & Capacitor control panel

TRIPPING CHARACTERISTICS:

- 1.0) IDMT: Over Voltage - $t = k / \log(\text{ovf})$ Sec
 Under voltage - $t = k / \log(2-\text{uvf})$ Sec
 K = time dial setting with range 0.1 to 1.0 Sec in steps of 0.1
 Ovf = (measured value/set value) x rated voltage
 Uvf = (measured value/ set value) x rated voltage
- 2.0) Definite Time : (0-300) Sec (time setting) in steps of 1 sec.

SPECIFICATIONS

Parameter	type : PNV NSP
SYSTEM VOLTAGE	380V,400V,415V & 433V- 3Ph 4W
FREQUENCY RANGE	45Hz to 65Hz.
PICK - UP	Over Voltage- 101% of set value Under Voltage-99% of set value
DROP- OUT	Over Voltage 1% below pick- up voltage Under Voltage-1% above pick -up voltage
RESPONSE TIME	< 100ms
SETTING RANGE	Under Voltage: $Uv < 0.99$ to $0.50 U_n$ in steps of 0.01 $Uv < <0.99$ to $0.50 U_n$ in steps of 0.01(High set) Over Voltage: $Ov > 1.01$ to $1.30 U_n$ in steps of 0.01 $Ov > >1.01$ to $1.30 U_n$ in steps of 0.01(High set)
% OF NEGATIVE SEQUENCE	(1-25%) in steps of 1%
NEGATIVE SEQUENCE DEFINITE TIME	(0-300) in steps of 1sec
NEGATIVE SEQUENCE INSTANTANEOUS TIME (NS>>) FOR >25%	(0.0 -5.0 Sec) in steps of 0.1
TIME FOR HIGH SET (UV<< & OV>>)	(0.0 -5.0 Sec) in steps of 0.1



Numerical over current and earth fault relay

IEEE Device code-50,51,50N & 51N

FEATURES:

- Three phase Non - Directional over current earth fault relay with IDMT and Definite time characteristics.
- High set over current and earth fault feature- Instantaneous operation.
- Modular Integrated Draw Out System with CT shorting.
- 2 line 16 character back lit LCD display
- Field selectable 1A or 5A.
- User selectable CT ratio (5-900)
- Enabling /disabling of High set
- Relay test facility with/ without tripping.
- Trip-Pulse or Hold operation for out put relay.
- High drop- out / pick- up ratio
- Programmable out put relays
- Fault recordings upto 100 faults.
- Low burden on CT
- Wide Aux. Input voltage range (both AC and DC)
- Communication protocol: MODBUS / DNP 3
- Choice of Definite time & 7 IDMT IEC-Curves, VI, NI, RI, EI, 3 sec, 1.3 Sec & LTD for Phase and Earth



SPECIFICATIONS

PARAMETER	TYPE : PNA - Series
ACCURACY OF OPERATING TIME <ul style="list-style-type: none"> ● FOR IDMT ● DEFINITE TIME ● INSTANTANEOUS 	±5% ±3% Less than 2 Cycles
RELAY RATED CURRENT (IN)	1A or 5A user selectable.
FREQUENCY	50Hz or 60Hz.
AUX. VOLTAGE RANGE	85V-275V AC/DC
PICK UP	103%
DROP OFF	95%
AC BURDEN	< 0.4VA for 5A <0.2VA for 1A @ unity pf.
DC BURDEN	<5W during non operated condition <7 W during operated condition
DIMENSIONS	151x181x195 mm (WxHxD)
MOUNTING	Flush
PANEL CUT OUT	151 x 157 mm + 0.1mm
CONTACT RATING	AC: 250 V @ 30 AMP DC: 24 V @ 30 AMPS, 2 C/O or 3 C/O
OPERATING TEMPERATURE	- 5 ^o to +55 ^o C



Numerical over current and earth fault relay

IEEE Device code-50,51,50N & 51N



RELAY PLUG SETTING RANGES:

Low set range (IDMT)

Low Set Current(I>)	Setting Range	Step	TMS	TMS range	TMS Step
I>	(0.5 to2.0)In.	0.01	t>	(0.01-1.6)	0.01
Ie>	(0.05 to0.80)In	0.01	t>	(0.01-1.6)	0.01

High set range

High set current (I>>)	Setting range	Step	Time	Range	Step
I>> Phase	(2-30)In	0.1	t>> phase	(0.0-1.6)Sec	0.1
Ie>> Earth	(0.5-16)In	0.1	t>> earth	(0.0-1.6)Sec	0.1

Definite Time plug and time settings.

Low set (I>)	Setting range	Step	Time setting range	Step
I> phase	(0.5-2.0)In	0.01	(1-160) Sec	0.1
Ie> Earth	(0.05-0.8)In	0.01	(1-160) Sec	0.1



Prok dvs®

AC voltage relay - LVM series

IEEE Device Code- 27, 59



FEATURES:

- Microcontroller based design
- Site selectable system voltages
- Continuous display of measured voltages
- 16 character 2 line back-lit LCD display
- Accurate reading for balanced and unbalanced load
- Wide range of auxiliary input voltages(AC &DC)
- Independent contacts for Under & Over Voltages
- Self reset and site selectable reset gap
- Built in (fixed) instantaneous under & over voltage high set trip
- User friendly setting modes
- Low power consumption
- Tropicalized and rugged

APPLICATION:

- Monitoring of under and over voltages in power generation and distribution systems
- To protect generators and AMF switch boards.
- For protection of synchronous and induction motors
- For transformer feeder panel
- Protection of capacitor control panel

SPECIFICATION:

PARAMETER	3 Ph.4W	3 Ph. 3W
AUX. VOLTAGE	85-275 V AC/DC	85-275 V AC/DC
SYSTEM VOLTAGE	220V/230V/240V/250V AC Site selectable	110V/380V/400V/415V AC Site selectable
OVER VOLTAGE SETTING RANGE	101%-120% in steps 1%	101%-120% in steps 1%
OVER VOLTAGE TRIP TIME	0-30 sec in steps of 0.1	0-30 sec in steps of 0.1
UNDER VOLTAGE SETTING RANGE	70%-99% in steps of 1%	70%-99% in steps of 1%
UNDER VOLTAGE TRIP TIME	0-30 sec in steps of 0.1	0-30 sec in steps of 0.1
RESET - GAP	1% to 5% in steps of 1%	1% to 5% in steps of 1%
ON - TIME DELAY	0-30 sec in steps of 0.1	0-30 sec in steps of 0.1
DEFAULT HIGH SET SETTING WITH INSTANTANEOUS TRIP	Fixed UV high set<70%of Un Fixed OV high set>120%of Un	Fixed UV high set<70%of Un Fixed OV high set>120%of Un
CONTACTS	Independent contact for Uv/Ov	Independent contact for Uv/Ov
CONTACT RATING	1C/O or 2C/O, 250V 8A AC 30V ,8A DC	1C/O or 2C/O, 250V 8A AC
INDICATIONS	Display of the voltage and nature of fault on LCD and LED indication for relay trip	Display of the voltage and nature of fault on LCD and LED indication for relay trip
DIMENSIONS	144x144x120 mm(HxWxD)	144x144x120 mm(HxWxD)
PANEL CUT OUT	137x137mm +0.1mm	137x137mm +0.1mm
MODEL	LVM 11-UV and OV relay LVM 02 UV relay LVM 03-OV relay	LVM 11A-UV and OV relay LVM 02A UV relay LVM 03A-OV relay

Reverse power relay

IEEE Device Code-32



FEATURES:

- Micro controller based, hence accurate and precise.
- Protection of generator / prime movers against reverse power
- Visual indication of power, pick-up and relay tripping.
- Display of reverse power on the LCD.
- Continuous display of sensing voltage, current, frequency and power factor with lead/lag indication.
- Wide Auxiliary voltage range from 85 - 275 V AC/DC.
- Cost effective and highly reliable compact design.
- Test Facility, allowing the user to check the NO and NC contacts of the relay.



APPLICATIONS:

Protection of Generator and Prime Mover.

SPECIFICATIONS

PARAMETER	Description
RATED CURRENT	5A
TRIPPING CURRENT	4% - 20% of I_n
TIME DELAY	0-20 Sec in steps of 0.1Sec
SENSING VOLTAGE	50-500V AC
FREQUENCY	40-60Hz
AUX. SUPPLY	85-275V AC/DC
OUT PUT RELAY	2C/O, 250 V 8A AC 30V, 8 A DC
DIMENSIONS	144 X 144X 105 (mm)
PANEL CUT OUT	137x137mm +0.1mm



FEATURES:

- Microcontroller based
- Accurate, reliable and tropicalized design
- Continuous display of frequency
- Wide frequency setting range
- Wide tripping time range
- Wide Aux. input voltage range 85-275 V AC/DC

APPLICATION:

- Generator and captive power plant
- As backup protection for mechanical over speed devices to avoid damage to prime mover
- Under frequency protection for field winding from excessive current and voltage regulator from over load
- Servo controllers and invertors

SPECIFICATIONS

PARAMETER	Type : HI-LO
RATED VOLTAGE	230V AC
AUX. SUPPLY	85V-275V AC/DC
FREQUENCY RANGE	40Hz-60Hz insteps of 0.1Hz
POWER SUPPLY BURDEN	<3Watts
CONTACTS	250V 8A AC 30V 8A DC Single Change Over
TURN OFF DELAY	0.05 -10 Sec step size 0.05 Sec Definite time
MOUNTING	Flush
DIMENSIONS	144x144x120mm
PANEL CUT OUT	137x137mm + 0.1 mm



Intelligent power factor correction relay (IPFC)

IEEE- Device code-55



APPLICATIONS:

- Industrial , Commercial applications -power factor is Critical & to be maintained at set target value
- Applications where energy conservation is vital.
To improve system efficiency & to avoid PF penalty.



SPECIFICATIONS

PARAMETER	IPFC
MEASUREMENT	True RMS
P.F RANGE	0.8 lag to 0.9lead
RECONNECTION TIME OF THE SAME CAPACITOR BANK	5-150 sec
RATED CURRENT	5A
APACITOR KVAR	Auto Detection of KVAR
CT RATIO	Manual entry
SWITCHING DELAY	programmable
CT POLARITY DETECTION	Auto Detection
STAGES	4,6,8,10 &12 stage
OPERATING LIMIT OF CURRENT	0.125 to 6A
OVER LOAD	+20 %Ib
SHORT TIME WITH STAND CURRENT	5 Ib for 1Sec.
POWER CONSUMPTION	0.65W
AUX. SUPPLY	230V, 50HZ ±20%
FREQUENCY	50 Hz / 60Hz.
QUADRANT OPERATION	4quadrant operation
LOCK OUT TIME FOLLOWING POWER FAILURE	90 sec lock out time
FAILURE ALARM FOR FAILURE TO ACHIEVE TARGET P.F	After 75 switching cycle
ALARM FOR EXCESSIVE HARMONIC DISTURBANCE	available
DISPLAY OF VARIOUS PARAMETERS(LCD)	Voltage, current, frequency phase angle, cos phi, kva kvar
SERIAL COMMUNICATION	RS-485 port Mmodbus protocol Device ID (1-31)
AUTO/MANUAL OPERATION	Yes
OUT PUT RELAY RATING	1C/O, 250V,8A AC, 30V, 8A DC
DIMENSIONS	144 X 144 X 105mm
PANEL CUT OUT	137 X 137 + 0.1mm



Prok dvs®

Voltage monitoring devices - Volt pro series

IEEE Device Code- 27,47,59

FEATURES:

MPVR Series (μ P BASED)

- Accurate Measurements
- Negative Phase Sequence Detection
- Fixed or Variable Time Delay
- 8 Char. 2line LCD back lit display
- Auto Reset
- Flush/Din rail mounting
- LCD indication of Healthy ,Operated
- Voltages & Phase Fail / Phase Reversal
- RS-485 com port.(Optional)

VD Series SOLID STATE

- Solid State Circuitry
- Negative Phase Sequence Detection
- Fixed or Variable Time Delay
- Auto Reset
- Fail Safe mechanism
- Din Rail Mounting
- LED indication of Healthy & Fault



APPLICATIONS

- Protection of Synchronous and Induction Motor of any HP rating
- Protection of Generators, AMF Switch Board
- Transformer Feeder Panel
- Distribution Boards
- Voltage Regulators
- Protection of UPS & Single Phase Application



SPECIFICATIONS:

TYPE	VD series Models (Solid State)	TYPE	MPVR Series Models (μ P Based Models)
VD-02	<ul style="list-style-type: none"> ● UV/OV & Ph .fail /Ph. Revs. ● 100mSec Tripping Time for OV,UV. 	MPVR-02	<ul style="list-style-type: none"> ● OV(105%-120% of Un) ● UV (80%-95% of Un) ● Ph .fail /Ph. Rev,.
VD-03	<ul style="list-style-type: none"> ● UV/OV & Ph .fail /Ph. Revs with Time Delay Trip time (0-15) sec 	MPVR-03	<ul style="list-style-type: none"> ● OV(105%-120% of Un) ● UV (80%-95% of Un) ● Trip Time Delay-(0.5-20) Sec ● Ph .fail /Ph. Rev.
VD-04	<ul style="list-style-type: none"> ● UV/OV Single Ph ● UV- (160 V-210 V) Step- 10 V ● OV-(240V-290V) Step- 10 V 	MPVR-04	<ul style="list-style-type: none"> ● Single Phase ● Reset gap-5Vto 20V ● UV- 160V to 210V, step 1% of 230V ● OV- 240V to 290V, step1% of 230V ● UV/OV- Trip Time Delay (0.5-20) Sec
VD-05	<ul style="list-style-type: none"> ● UV With Ph. Fail/Phase Rev with time delay Trip time (0-15) Sec 	MPVR-05	<ul style="list-style-type: none"> ● UV-(80%-95% of Un) ● Trip Time Delay-(0.5-20) Sec ● Ph .fail /Ph. Rev
VD-06	<ul style="list-style-type: none"> ● OV With Ph. Fail/Phase Rev with time delay Trip time (0-15) Sec 	MPVR-06	<ul style="list-style-type: none"> ● OV (105%-120% of Un) ● Trip delay-(0.5-20) Sec ● Ph .fail /Ph. Rev
VD-07	<ul style="list-style-type: none"> ● 90% of Un Fixed UV with Ph. Fail/Ph. Rev with time delay Trip time (0-15) Sec 	MPVR-07	<ul style="list-style-type: none"> ● 90%(Un) Fixed Under Voltage ● Trip Time Delay-(0.5-20) Sec ● Ph .fail /Ph. Rev

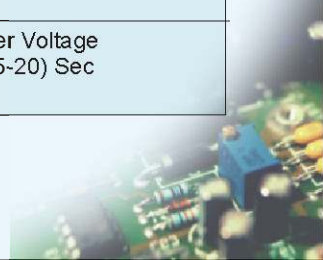

Voltage monitoring devices

IEEE Device Code- 27,47,59



SPECIFICATIONS:

PARAMETER	Type : MPVR Series (μ P based)	VD series (Solid State)
SYSTEM VOLTAGE	415VAC \pm 20%,50Hz. 3 \emptyset 4W	415V AC \pm 20% 50Hz, 3 \emptyset 3W
SENSING AUX. VOLTAGE(UN)	110V/230V/415V AC 20%,50Hz	110V/230V/415V AC 20%,50Hz
AUXILIARY VOLTAGE	85-275V AC/DC	NA
CONTACTS & RATING:	2 C/O contacts,250V 8 A AC 30V,8A DC	2 C/O contacts,250V 8 A AC 30V,8A DC
TRIP VOLTAGE SETTINGS: A)UNDER VOLTAGE B)OVER VOLTAGE C)PHASE TO PHASE UNBALANCE	80%-95% of Un Step-1% 105%-120% of Un Step-1% NA	80%-95% of Un Step- 3% 105%-120% of Un Step- 3% 100V fixed
TRIP TIME DELAY A)PHASE FAIL/PHASE REVERSAL B)UNDER/OVER VOLTAGE	Approx: 2Sec 0.5-20 Sec, Step-0.5Sec	3Sec - Fixed. 0-15 Sec ,Step 3Sec 100msec Fixed (Depends on model)
ON - TIME DELAY	0.5 -10Sec, Step size 0.5Sec	3 Sec Fixed.
RESET GAP(MAX): A)UNDER/OVER VOLTAGE B)UNBALANCE VOLTAGE	5-20V Step-5V 10V \pm 2V	NA 5-10V
RESETTING MODE	Auto	Auto
INDICATION: A)GREEN LED B)RED LED	1) Phase Fail / Phase Reversal 2) Under Voltage trip indication 3) Over Voltage trip indication	System Healthy 1) Phase Fail /Phase Reversal / Phase Unbalance 2) Under Voltage trip indication 3) Over Voltage trip indication
INDICATION: LCD	DISPLAY : ● Phase Voltages ● Phase Reversal ● Phase Failure ● OV/UV Trip Value Indication.	NA
MOUNTING	Din & Flush	Din mounting
POWER CONSUMPTION	<4VA	<4VA
INSULATION	2KV, 50Hz for 1min	2KV, 50Hz for 1min.
DIMENSION A)FLUSH B)DIN	96*96*70mm(W*H*D) 80*94*75mm(W*H*D)	NA (75 * 95*75mm)-Din
MODELS:	MPVR-02,MPVR-03 ,MPVR-04 MPVR-05,MPVR-06,MPVR-07	VD-02. VD-03 VD-04 VD-05,VD-06,VD-07
OPERATING TEMP	-5° C to +55° C	-5° C to +55° C



Phase failure relay

TYPE: PHASE PHEE

IEEE Device code-47

FEATURES:

- Phase Reversal Detection
- Low Power Consumption
- Selectable percentage Unbalance Settings
- Auto / Manual Reset
- Fail Safe System
- Accurate, Reliable and Tropicalized Design
- Din Mounting

APPLICATIONS

- Suitable for Motors of any HP rating
- Power supply Distribution Boards
- Agriculture Pump Control Panels



SPECIFICATION:

PARAMETER	PHASE PHEE
SYSTEM VOLTAGE(UN)	415V AC 50 Hz 3 Phase.
TRIPPING DELAY	2.5 sec (Fixed)
UNBALANCED VOLTAGE SETTING	10% or 20% of Un
RESET	Manual/Auto
AUXILIARY VOLTAGE	110 / 230 / 415 VAC 50 Hz
RELAY CONTACTS	2C/O potential free contacts 250V 8A AC , 30 V 8 A DC
DIMENSIONS	75x95x75mm
MOUNTING	Din
OPERATING TEMP	-5° C to +55° C



Tap position indicator



FEATURES:

- Seven segment display
- On/off switch with lamp indication for power supply status
- Potentiometer for trimming for lead compensation
- Panel mounting
- Robust and rugged design

APPLICATIONS:

- OLTC panel- for indicating tap position



SPECIFICATIONS

PARAMETER	TYPE : TPI 005
AUX. VOLTAGE	110 V, 230V or 415V AC \pm 15%
RESISTANCE TEL-TRANSMITTER	1kilo Ohms per step. 3 wire connection.
DISPLAY	1-99 position , 2digit 7 segment display
ACCURACY	Tolerance \pm 2%
LEAD COMPENSATION	Through potentiometer adjustment (in-front facia)
MOUNTING	Panel mounting
OPERATING TEMP.	-5° C to +55° C
DIMENSIONS	96x96x70mm
PANEL CUT OUT	90mmx90mm+ 0.1 mm



Prok d's®

Digital Meter - PDM Series

FEATURES:

- Accuracy Class 1.0
- Solid State Design
- Built in transducers
- Built in Selector Switch or Without Selector Switch
- Compact in Size With Aesthetic Value
- 7 segment red LED Display
- Tropicalised Design and Time Tested
- Low Power Consumption

APPLICATIONS

- Electrical Distribution Control & Relay Panel
- Power Control Centers
- Motor Control Centers
- Generator Control Panels
- Test Benches and Laboratory Equipments
- Wind Energy and Co-Generation Plants
- Air Conditioning /Refrigeration Plants



KW and PF METER

PARAMETER	KW meter		KW & PF meter	
	Nominal	Range	Nominal	Range
AUX. SUPPLY VOLTAGE (AC)	110V 110V	80-130V 80-130V	230V 230V	160-300V 160-300V
SENSING CT	5.0 A 1.0A	0.25-6.0A 0.05-1.2A	5.0 A 1.0A	0.25-6.0A 0.05-1.2A
SENSING INPUT VOLTAGE THREE PH.3W	415V	300-500V	415V	300-500V
POWER FACTOR RANGE	-	-	0.5 lag-upf-0.5lead	
FULL SCALE READING	3.59KWxMF or 999KW(direct reading)		0.99lag or lead	
ACCURACY	Acc. class 1.0(±(1%of full scale reading+ 1count)		Acc. class 1.0(±(1%of full scale reading+ 1count)	
BURDEN	0.26VA max/phase (Voltage / Current Input) 3VA max on Aux. supply		0.26VA max/phase (Voltage / Current Input) 3VA max on Aux. supply	
OPERATING TEMP.	-5° to + 55°C		-5° to + 55°C	
MOUNTING	Flush		Flush	
DIMENSIONS (IN MM)	96x96x120		96x96x120	
PANEL CUTOUT	90x90+.1mm		90x90+.1mm	
ALSO AVAILABLE IN DIMENSIONS	144x144x95		144x144x95	
PANEL CUT OUT	137x137+.1mm		137x137+.1mm	



Digital Meter - PDM Series

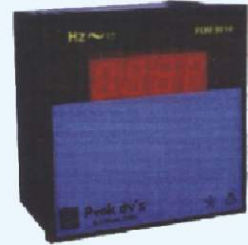

SPECIFICATION: VOLTMETER, AMMETER & FREQUENCY METER

PARAMETER	Ammeter		Voltmeter		Frequency meter	
	Nominal	Range	Nominal	Range	Nominal	Range
AUX. SUPPLY VOLTAGE (AC)	110V 230V	80-130V 160-300V	110V 230V	80-130V 160-300V	110V 230V	80-130V 160-300V
SENSING CT	5.0 A 1.0A	0.25-6.0A 0.05-1.2A	- -	- -	- -	- -
SENSING INPUT VOLTAGE SINGLE PHASE THREE PH. 3W/4W AC	- - - -	- - - -	230.0 63.4V 110V 415V	160-300V 50-76V 80-130V 300-500V	- - - -	- - - -
SENSING FREQUENCY INPUT	-	-	-	-	50Hz	20Hz-99.99Hz
ACCURACY	Acc.class 1.0(\pm (0.1%of full scale reading+1 count))		Acc.class 1.0(\pm (0.1%of full scale reading+1 count))		Acc.class 1.0(\pm (0.1%of full scale reading+1 cont))	
BURDEN	0.25VA max/phase (Voltage/current Input) 3VA max on Aux. Supply		0.25VA max/phase (Voltage/current Input) 3VA max on Aux. supply		3VA max on Aux. supply	
OPERATING TEMP.	-5° to +55°C		- 5° to +55°C		- 5° to +55°C	
MOUNTING	Flush		Flush		Flush	
DIMENSIONS IN MM	96x96x70		96x96x70		96x96x70	
PANEL CUTOUT	90x90+.1mm		90x90+.1mm		90x90+.1mm	
DIMENSIONS ALSO AVAILABLE IN	144x144x95		144x144x95		144x144x95	
PANEL CUT OUT	137x137+0.1mm		137x137+0.1mm		137x137+0.1mm	



Prok dvs®

Three phase energy meter

COUNTER TYPE

FEATURES

- True RMS Measurements
- Accuracy class 1.0
- Confirms to IEC 62052-11, 62053-21
- Compact size & ideal for industrial environment
- Accurate, reading for balanced and unbalanced loads
- Gives tamper indication
- Accurate under rapid current fluctuation
- No mechanical wear and tare
- Accurate, reliable and tropicalized design
- No auxiliary supply is essential



APPLICATION

- Electrical panels - HT and LT panels
- Generator Panel and captive power plant
- Furnaces and Ovens
- Special OEM application
- Test benches and laboratory equipments

SPECIFICATIONS

MODEL NO AND WIRING	PDM9022 - 3Ph. 4 - Wire, PDM 9022A - 3 Ph. 3 - Wire, PDM 9022 1P (1Phase)
ACCURACY CLASS	Class 1.0
FREQUENCY	50Hz ± 5%
DISPLAY	5 + 1 digit
SYSTEM VOLTAGE	415VAC/ 110VAC
OPERATING VOLTAGE	- 40% to 20% of phase to neutral voltage
PHASE REVERSAL INDICATION	By glowing of red LED
AUX. VOLTAGE	Self powered from input voltage
OPERATING TEMP. RANGE	- 5°C to +55°C
POWER CONSUMPTION	Less than a watt / phase
CT - RATIO SELECTION	Fixed i.e. Used specified
MOUNTING	Flush mounting
DIMENSION	96 x 96 x 70mm



Three phase energy meter

LCD TYPE



FEATURES:

- True RMS Measurements
- Accuracy class 1.0
- Continuous display of the measured - KWH
- User selectable CT - ratio
- Confirms to IEC 62052-11, 62053-21
- Compact size & ideal for industrial environment
- Accurate reading for balanced and unbalanced loads
- 2 line 16 character back lit LCD display
- Gives tamper indication
- Accurate under rapid current fluctuation
- Direct reading-CT operated
- No mechanical wear and tare
- Accurate, reliable and tropicalized design

APPLICATIONS

- Electrical panels - HT and LT panels
- Generator Panel and captive power plant
- Furnaces and Ovens
- Special OEM application
- Test benches and laboratory equipments

FEATURES:

Prok dvs® make PDM - series is the state of the art Three Phase Energy Meter. It uses reliable solid state along with Micro controller and non-volatile memory. All measurements fall with in the accuracy class of 1.0. The design incorporates anti tamper features, which makes the meter dependable in field use. Satisfactory operation is guaranteed in the frequency range 50HZ \pm 5%. CT ratio are field programmable. The design is tropicalised and rugged.

MODEL NO. AND WRING	PDM9023-3Ph. 4-Wire, PDM9023A-3PH. 3-Wire, PDM9023RS-RS-485 port 3PH 4 Wire, PDM9023RS-RS-485 port 3PH 3 Wire, PDM9023 1P[1Ø]
ACCURACY CLASS	Class 1.0
FREQUENCY	50Hz \pm 5%
DISPLAY	6 + 1digit
SYSTEM VOLTAGE	415VAC/110VAC
OPERATING VOLTAGE	-40% to 20% of phase to neutral voltage
PHASE REVERSAL INDICATION	By glowing of Red LED
AUX. VOLTAGE	230 VAC ,50 HZ
OPERATING TEMPERATURE RANGE	-5° C to +55° C
CT-RATIO RANGE /5A & 1A	5/5A.....3000/5A- direct reading range 1/1A.....1000/1A- direct reading range
CT- RATIO SELECTION	Field selectable
MOUNTING	Flush mounting
DIMENSION	96X96X70mm



Prok dvs®

Three phase energy meter - DUAL

FEATURES:

- True RMS Measurements
- Accuracy class 1.0
- Continuous display of the measured KWH
- User selectable CT ratio
- Confirms to IEC 62052 -11 , 62053-21
- Compact Size & ideal for industrial environment
- Accurate, reading for balanced and unbalanced loads
- Two line 16 character back lit LCD display
- Gives tamper indication
- Accurate under rapid current fluctuation
- Direct reading CT operated
- No mechanical wear and tear
- Accurate, reliable and tropicalized design
- Records energy from two sources
- Energy recorded from either sources can be read at any instant of time



APPLICATIONS

- Electrical panels HT and LT panels
- Generator panel and capacitive power plant
- Furnaces and ovens
- Special OEM application
- Test benches and laboratory equipments.

LCD TYPE ENERGY METER

PARAMETER	
MODEL NO AND WIRING	PDM9025-3Ph ,4 Wire PDM9025A-3Ph,3 Wire PDM9025RS -3 PH 4 wire PDM9025A,RS -3 PH 3 wire.
ACCURACY CLASS	Class 1.0
FREQUENCY	50Hz±5%
DISPLAY	6 +1Digit
SYSTEM VOLTAGE	415V AC/110V AC
MOUNTING	Flush
DIMENSIONS (MM)	96x96x70
PANEL CUTOUT	90x90+.1mm
AUX.VOLTAGE	230 V AC 50 HZ



Dual energy meter with Power Monitor



FEATURES:

- True RMS measurements
- Accuracy class 1.0
- 2 Line, 16 Character back lit LCD display.
- Display parameters
 1. E.B Energy (6.3 format)
 2. D.G Energy (6.3 format)
 3. Line voltages (Vr, Vy, and Vb with respect to neutral)
 4. Line currents (Ir, Iy, and Ib).
 5. Line Frequency.
 6. Average power factor lag or lead
 7. Active power- R ph, Y ph, B ph & summation
 8. a) EB On hours
b) DG On hours
- L.E.D Indications
 1. Presence of phases (R, Y, B)
 2. Reverse polarity
 3. Presence of D.G source
- Confirms to IS-13779/ IEC-62052-11& IEC-62053-21
- CT ratio- selectable from 5/5 to 3000/5
- RS 485 PORT Modbus protocol
- Compact and ideal for industrial environment



APPLICATIONS

- Electrical panels HT and LT panels
- Generator panel and capacitive power plant
- Furnaces and ovens
- Special OEM application
- Test benches and laboratory equipments.

Mod bus protocol: Address and parameter data type details

Address	Description	Data Type	Ct type
0000	Single/Dual kWh	Unsigned Int	1= single 2=Dual
0001	CT -type	Unsigned Int	1=/1, 5=/5
0002	CT -ratio	Unsigned Int	-
0003	Phase R- VRMS	Unsigned Int	-
0004	Phase Y- VRMS	Unsigned Int	-
0005	Phase B- VRMS	Unsigned Int	-
0006	Phase R- IRMS	Float	-
0008	Phase Y- IRMS	Float	-
0010	Phase B- IRMS	Float	-
0012	Frequency	Float	-
0014	EB- Energy	float	Format 6.3
0016	DG- Energy	float	Format 6.3
0018	pf	float	-
0020	Reactive power sign	Unsigned Int	0= lag 1=lead
0021	Phase R - kW	float	-
0023	Phase Y - kW	float	-
0025	Phase B - kW	float	-
0027	Total- kW	float	-
0029	EB On Hour	float	-
0031	DG On Hour	float	-



Prok dv's®

Dual energy meter with Power Monitor

SPECIFICATIONS

PARAMETER	Technical Specifications
VOLTAGE	415V line to line [same as 3x240 V P-N]
CURRENT FREQUENCY	5 A through CT 50Hz +/- 5%
STARTING CURRENT IN PHASE	0.2% of Ib
NO LOAD TEST	At 80% Vref & 120% Vref
ACCURACY (ACTIVE) ACCURACY (CURRENT) ACCURACY (VOLTAGE)	Class 1.0 2% to 120% of nominal 80% to 120% of nominal
DISPLAY	2 line back- lit 16 characters LCD Display
DISPLAY PARAMETERS A. CURRENT[IR,IY&IB] B. VOLTAGE [L-N] C. FREQUENCY D. POWER FACTOR E. KILO WATT F. KILO WATT HOUR J. CUMULATIVE KWH K. DG RUN HOURS. L. EB RUN HOURS.	Both on EB & DG Both on EB & DG Both on EB & DG Both on EB & DG Both on EB & DG Both on EB & DG Both on EB & DG
SOFTWARE & COMMUNICATION	RS485 serial communication port with MODBUS RTU Protocol
MEMORY	Non volatile memory independent of battery backup
FIELD CONFIGURABLE	CT Ratios
CALIBRATION	Software
DIMENSIONS	Flush mount black ABS case with a 96*96*70 mm(W*H*D)
SPECIFICATIONS MEASUREMENTS AUXILIARY SUPPLY FREQUENCY SYSTEM VOLTAGE REVERSE POLARITY CT RATIO-FIELD PROGRAMMABLE	4 Quadrant True RMS value 85-275 V AC/DC 50Hz +/- 5% 415 V AC/110 V AC Indication by red LED a) Direct reading upto 40Amps (CT mounted in the unit) b) 5/5 to 3000/5 in steps of 5 field selectable
TEMPERATURE	- 5°C to + 55°C
POWER CONSUMPTION	Less than 1 watt/phase
MODELS	PDM9025-3Ph.4W

- Note: 1. Energy meter reading Overflows after recording- 999999.999 KWH
2. Energy EB On Hour / DG On Hour reading Overflows after recording- 99999.59 H



FEATURES:

- Accuracy class 1.0
- Micro Controller based
- Built- in Transducers
- Built -in Selector Switch
- Built -in HOLD Facility
- Field Selectable CT Ratio
- Compact in size
- 2-Line, 16- Character back lit LCD Display
- Tropicalised Design and Time Tested
- Low Power consumption
- Scroll Facility
- Continuous display of line Voltage, Phase Voltage, Three Phase Currents and system frequency



APPLICATIONS:

- Electrical Distribution Control & Relay Panel
- Power Control Centers
- Motor Control Panels
- Test Benches and Laboratory Equipments
- Wind Energy and Co-Generation Plants
- Air Conditioning / Refrigeration Plants

SPECIFICATIONS

PARAMETER	AMMETER		VOLTMETER		FREQUENCY METER	
	Nominal	Range	Nominal	Range	Nominal	Range
AUX. SUPPLY VOLTAGE AC	110V 230V	80-130V 160-300V	110V 230V	80-130V 160-300V	110V 230V	80-130V 60-300V
SENSING CT	5.0 Amps 1.0 Amps	0.25-6.0A 0.05-1.2A	- -	- -	- -	- -
SENSING INPUT VOLTAGE AC	- - -	- - -	63.5V 110V 230V	50-76V 80-130V 160-300V	Frequency -	40 - 60 Hz - -
THREE PHASE 3 WIRE/	Acc.class1.0[±(1.0% of Full Scale reading + 1 count)]					
CT RATIO	5/5 to 2000/5		-		-	
BURDEN	0.25VA max/ Phase (Voltage / Current Input)		0.25VA max/ Phase (Voltage / Current Input)		-	
AMBIENT TEMPERATURE	-5°C + 55°C					
HUMIDITY	<95% RH Non condensing					
MOUNTING	flush					
DIMENSIONS	96 X 96X70mm					
PANEL CUT OUT SIZE	90mmX90mm + 0.1 mm					
MODELS	PDM 9030 - VAF METER PDM 9030VF - VF METER PDM 9030AF - AF METER					



Prok dvs®

Auto source change over with current limiter - ACCL

ACCL for Single phase and three phase application

FEATURES:

- While monitoring the Mains supply, it allows full load current.
- While monitoring the Generator supply, Allows only limited load and functions as load limiter as per desired power and current.
- Current sealing (while monitoring the Generator) will be preset at factory.
- Whenever the load current exceeds the preset limit ,power is automatically switched off instantaneously and reset automatically after 9 seconds and trips again if the over load still exists, this cycle is(3Sec ON & 6Sec OFF) is repeated every 9 seconds .ACCL enters Lock Out mode after five ON & OFF cycles if over loading of the DG persists . The unit can be reset by switching off the supply to the ACCL. However tailor made units i.e. field adaptable and made as per customer requirements it is a micro controller based product.
- Display of each phase Voltages, Currents and power (In three phase ACCL)
- Over voltage and Under Voltage cut off for both EB/DG(In three phase ACCL)
- On resumption of the mains supply it automatically changes over, and full load can be drawn.



BENEFITS:

- Microprocessor based, hence precise and accurate.
- It measures the load current at which cut-off should take place .
- Over voltage & Under voltage cut off for EB & DG
- Simplifies electrical complexity
- Significant saving on wall space & wiring.
- Product guaranteed for 2 years
- In the event of change over from DG to EB the phase is first isolated, then the neutral is disconnected (Single Phase ACCL)
- Tropicalized and rugged design.
- Three phase ACCL are enclosed in aesthetically made powder coated sheet metal enclosures.
- Single phase ACCL are enclosed ABS grade thermoplastic.
- LED indication of all operational status
- 2 line 16 character LCD display with back lit, displaying voltage, current and power while monitoring the DG. (Three Phase ACCL)
- Mechanical inter lock between contactors in three phase models.
- Wiring connections- using insulated feed through terminal blocks.
If load current exceeds the rated current of contactor ACCL trips.

SPECIFICATIONS:

Single Phase ACCL.

- EB input: 220V AC 50Hz
- DG input: 220V AC 50Hz
- Red LED ON : load on EB
- Green LED ON; load on DG
- Green LED blinks: DG ON, load on EB
- Green LED turns Red: ACCL in lockout mode
- Relay Contact rating: 250V AC, 30



Auto source change over with current limiter - ACCL

ACCL for Single phase and three phase application



SPECIFICATIONS:

Three Phase ACCL.

- EB input: 415V AC 50Hz 3ph 4wire
- DG input: 415V AC 50Hz 3ph 4wire
- LCD display : 2Line 16 character backlit LCD display
- LED (R,Y&B): Indicates presence of EB/DG
- Contact rating:250V AC, 40 A/63A(Depending on the model)

MODELS:

Single Phase Model	EB-Load	DG-Load	Mounting	Dimensions W X H X D (mm)
ACCL - 1 Phase EB 1 Phase EB	30A	0.5-20A	DIN	70 X 105 X 60
Three Phase Model				
ACCL - 3 Phase EB 3 Phase DG	40A	1-40A	SURFACE	153X137X200
ACCL - 3 Phase EB 3 Phase DG	63A	1-63A	SURFACE	280X175X193
ACCL - 3 Phase EB 1 Phase DG			on Request	
ACCL - 1 Phase DG 3 Phase DG			on Request	

Note: Other Current Ratings / Models are available on request depending on the bulk ordering quantity.



BATTERY CHARGER -PDBC Series

Switch Mode Power Supply

APPLICATIONS:

- Wide Input Voltage Tolerance
- High Efficiency
- Over load and Short Circuit Protection
- Very low load and line Regulation
- Out Put Power up to 480W
- Rugged, Reliable and Tropicalized Design
- Natural convention cooling
- Wide operating Temperature
- Input and out put termination with LED indication
- Fuse(slow blow) protection at input
- Inrush current limit through NTC thermister
- Surge / Transient voltage protection through MOV
- Common mode filter for EMI/EMC



TECHNICAL SPECIFICATION:

PARAMETER	Specification
INPUT VOLTAGE RANGE	90V -270 V AC 50Hz, 160V-270V AC Hz
NOMINAL OUT PUT VOLTAGE	12VDC 30VDC 24VDC 110VDC
RATED OUT PUT CURRENT	1.2ADC 8ADC 2A DC 10ADC 4A DC 15ADC 5A DC 20ADC
OUT PUT VOLTAGE REGULATION	0.5V
SWITCHING FREQUENCY	130KHz
EFFICIENCY	>80%
RIPPLE/ NOISE PEAK TO PEAK	250mV with out battery connected at the out put
MINIMUM LOAD CONDITION	No minimum load requirement for voltage regulation or operation of the float charger
INPUT / OUTPUT CONNECTOR	PCB mounted terminal block
STORAGE TEMPERATURE	-20°C to 65°C
OPERATING TEMPERATURE	-5 °C to + 55 °C
LED INDICATIONS	AC input Red LED Out put Voltage-Green LED
PROTECTIONS	<ul style="list-style-type: none"> ● Fuse at input(slow blow) ● Isolation 2KV between input &out- put ● Protection against out- put short circuit ● Protection against surge at input ● Over temperature protected with auto restart
COOLING	Natural convention / Fan

DIMENSIONAL DRAWING

MOUNTING: FLUSH

For : Microprocessor Based & Solid State Protection Relays & Digital Panel Meters

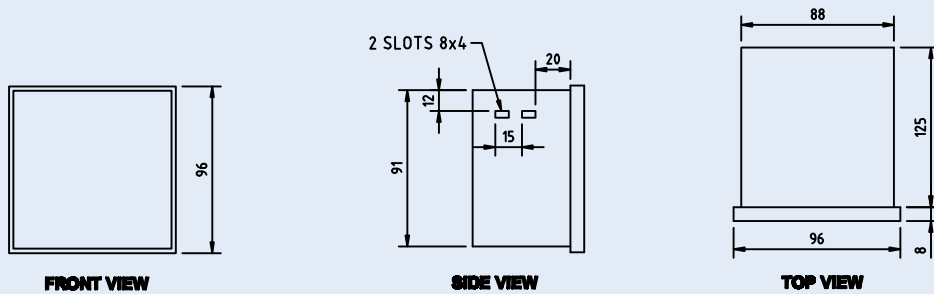

MOUNTING: DIN

For : Solid State Relays

For : Microprocessor Based

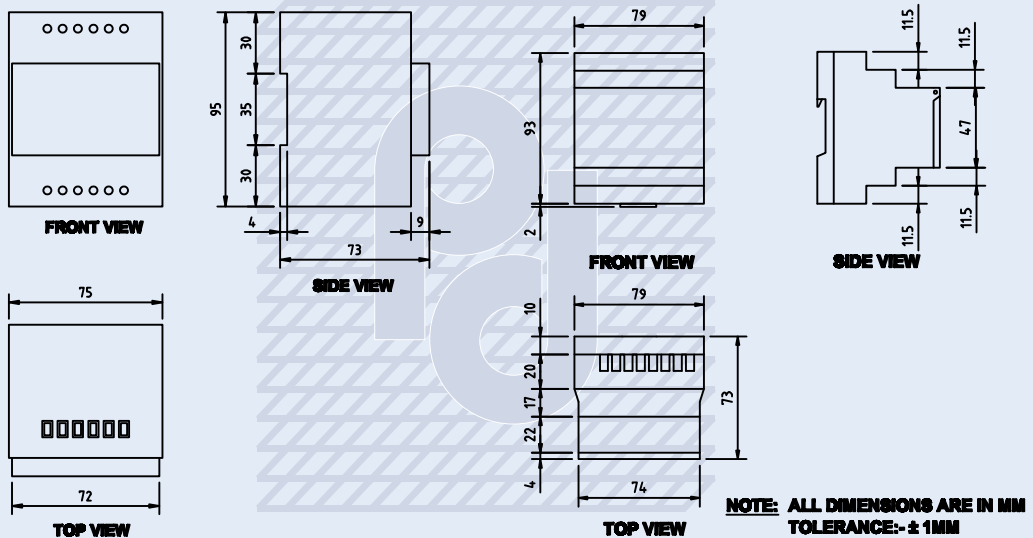

MOUNTING: FLUSH

For : Microprocessor Based VOLTAGE RELAYS [LVM Series], INTELLEGTENT POWER FACTOR CORRECTION RELAY, REVERSE POWER RELAY & DIGITAL METERS [144 x 144 mm]

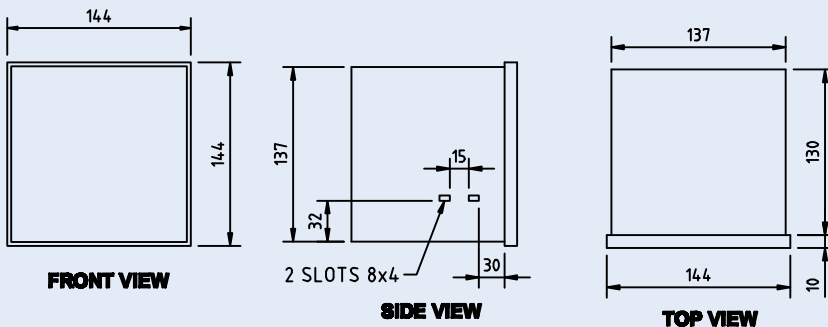

NOTE: ALL DIMENSIONS ARE IN MM TOLERANCE:- ± 1MM

MOUNTING: FLUSH

For : NUMERICAL OVER CURRENT & EARTH FAULT RELAY PNA Series

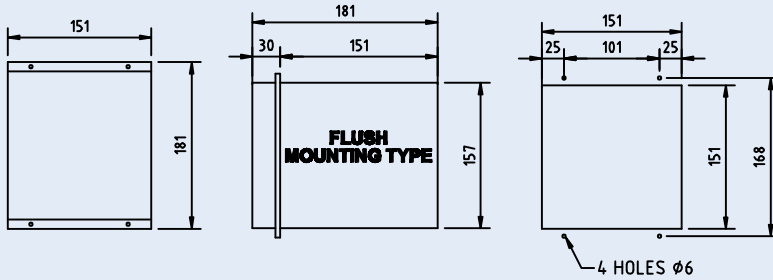

**NOTE: ALL DIMENSIONS ARE IN MM
TOLERANCE:- ± 1 MM**

MOUNTING: FLUSH

For : NUMERICAL OVER VOLTAGE & UNDER VOLTAGE RELAY PNV NSP Series

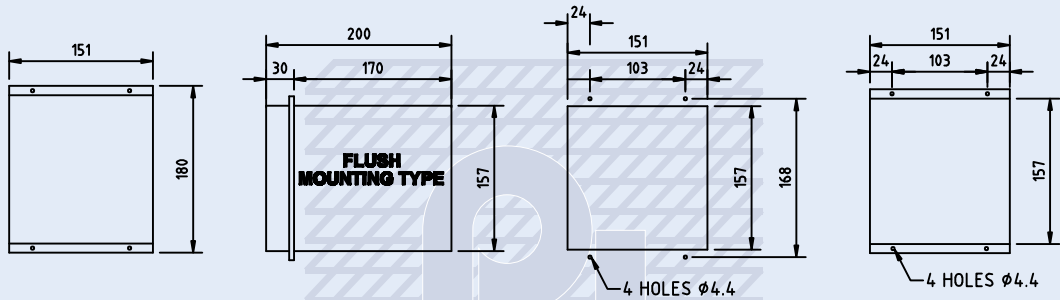

For : AUTO SOURCE CHANGE OVER CUM CURRENT LIMITER [ACCL]

3-ph ACCL - (63Amps)

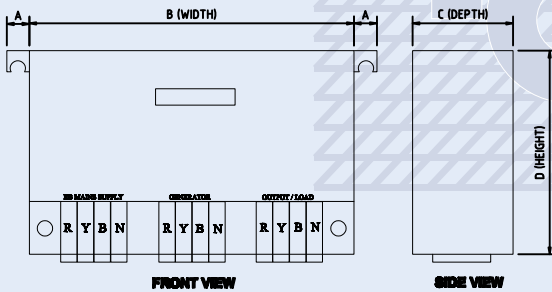

DIMENSIONS ARE IN MM				
FRAME (63Amps)	A	B	C	D
	13	280	175	183

Single Phase ACCL

3-ph ACCL - (upto 40Amps)

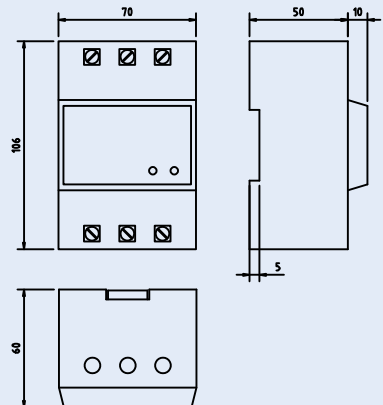
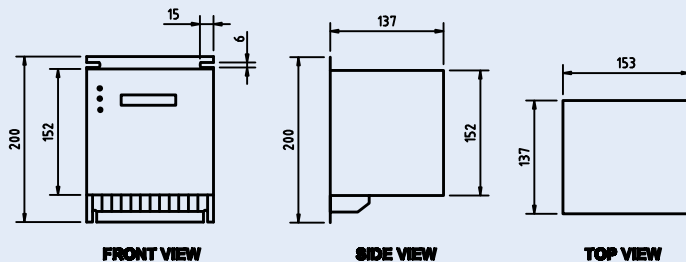

For : SMPS / BATTERY CHARGERS

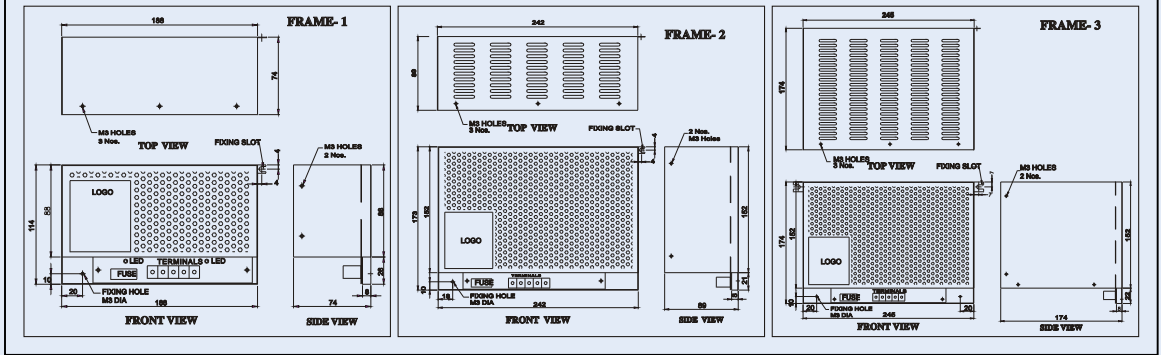



Notes



SOME IMPORTANT CLIENT LIST

- LARSEN AND TOUBRO LTD
- SIEMENS LTD
- GE POWER CONTROLS LTD
- ABB LTD
- CONTROLS & SWITCHGEARS COMPANY LTD
- SCHNIEDER ELECTRIC COMPANY
- RELIANCE GROUP OF COMPANIES
- INFOSYS
- WIPRO LTD
- ITPL
- IBM COMPUTERS
- INTEL COMPUTERS
- ITC GROUP OF COMPANIES
- DEPARTMENT OF SPACE
- ONGC
- TNEB
- JVVN
- WESTERN COAL FIELDS LTD
- SINGARENI COLLIERIES LTD
- HINDUSTAN ZINC LTD
- SOUTH EASTERN COAL FIELDS
- HUTTI GOLD MINES LTD
- I.O.C.L
- O.I.L
- POWERICA LTD
- TYCO ELECTRONICS LTD
- MANTRI GROUP
- SJR GROUP
- H.M.CONSTRUCTIONS
- ALPINE HOUSING PVT LTD
- PRESTIGE DEVELOPERS
- CONCORDE DEVELOPERS
- VASWANI BUILDERS AND DEVELOPERS
- SOBHA DEVELOPERS
- OCEANUS DWELLINGS LTD



Total Reliability in Power System Protection & Monitoring

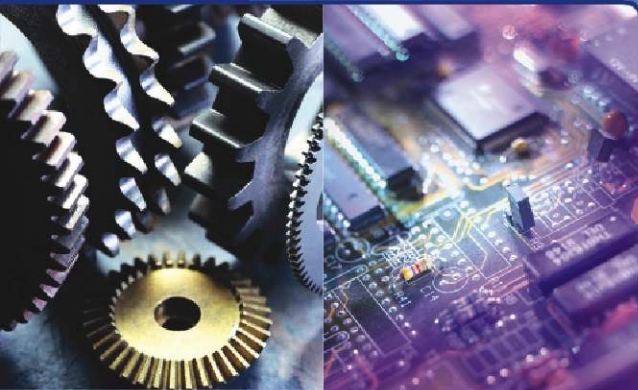

Corporate Office:

Prok Devices Private Limited

2930 "SIMHADRI" 14th Cross, off K.R. Road Banashankari 2nd Stage
Bengaluru - 560 070 INDIA

Contact : +91-80-26760718, 26761719
Fax : +91-80-26761720

E-mail : prokdvs@blr.vsnl.net.in, prokdvs@vsnl.com

http// : www.prokdvs.com

